



UK translation of Guidance Book: Construction/Adaptation/renovation of chimney flues

This guide is a summary of technical documents and norms and is not a substitute for building regulations or professional bodies' guides.

This guide will help installers to put together systems following building regulations for twin wall chimneys, single wall chimneys and flexible chimney liners.

You will find guidance for all solid fuel appliances used commonly in domestic situations.

All rights reserved. Reproduction is strictly forbidden without previous agreement with Poujoulat. Poujoulat reserves the right to change part of or all product or line of product in the customer interest.

INDEX

- Glossary
- Label example
- Flue components designation
- Example of domestic installation
- Sizing charts for open fires
- Flues drawings
- Prefabricated chimney top
- Metal chimneys
- Distances from combustibles materials
- Flue pipe connectors
- Firestop plates
- Adaptors and offset
- Pre-installation work
- Flue extension
- Installation drawings: flexible and rigid
- Annexe: sweeps, air inlet
- Combustibles
- Chimney identification plate
- Building regulations
- Clean air act
- Information

GLOSSARY

Twin wall Chimney – Sectional chimney system with an inner flue and outer casing separated by thermal insulation.

Multi-fuel system - A system capable of supporting combustion of different fuels, usually Coal, Smokeless Fuels and Wood. Usually this would refer to stoves or chimney systems.

Flexible Flue Liner - Single or double wall flue used for lining which can be flexed around offsets, usually constructed of stainless steel

Twin Skin Liner – Flexible liner that is manufactured so that the inner of the flue is smooth to reduce surface resistance and improve the chimney characteristics.

Safety distance – Minimum distance permitted between the flue and combustible materials within the fabric of the building.

Fire-stop plate - Product made to ensure that the safety distance from the outside wall of a twin wall chimney to combustible materials is maintained where the chimney passes floors and walls.

Thermal resistance – Resistance to heat transfer through the walls of a chimney or flue.

Domestic installation

Each chimney must only be connected to one appliance.

A chimney is installed to remove the products of combustion from the building. The flue is continuous from the appliance connector to the top of the chimney.

The flue pipe connector is the link between the appliance and the chimney.

Each type of appliance has its own set of rules:

- Open fires
- Stoves

There are 3 responsible parties to any installation:

- The choice of product and its suitability for the application is the responsibility of the designer of the chimney.
- The installation is the responsibility of the installer. The installer must ensure that the product is installed in line with building regulations and the manufacturer's installation instructions.
- The manufacturing quality of the product is the responsibility of the manufacturer.

Designation of Flue System Parts:

BS EN 1856 introduces a requirement for a certified factory production control system, which is in addition to any existing ISO 9000 factory quality scheme. This ensures, through continuous assessment and external quality audits, that the manufactured product conforms with the performance designation of the product. Chimney products manufactured, tested and approved to BS EN 1856, are entitled to carry the CE mark. If a product is not CE marked then it does not conform to BS EN 1856

How to read the EN1856 designation

A simple code will give the user information about the suitability of the system for different applications. This information includes;

Temperature Class

The following temperature classes exist:

T80, 100, 120, 140, 160, 200, 250, 300, 400, 450, 600

This indicates the normal maximum operating temperature of the chimney. For solid fuel T450 or above should be used.

Pressure Class

The following pressure classes exist:

N1, N2, P1, P2, H1, H2

The pressure class relates to the product's suitability and gas tightness when used on positive pressure applications up to 200pa (P), negative (N) draught applications, and high positive pressure (H) applications and is further classified as to the degree of leakage allowed with either a 1 or 2, with 1 having the lowest leakage rate.

For solid fuel applications where the chimney operates under negative draught conditions, an N1 designation would be suitable.

Condensate Resistance Class

The following condensate resistance classes exist:

W=Wet D=Dry

This classification determines the product's ability to contain condensate within the chimney. A chimney serving a condensing appliance would require a wet (W) classification, as the flue gas temperature would be below the water dew point. A solid fuel chimney could use a dry (D) classification as it usually operates at a high enough temperature to avoid condensate.

Corrosion Resistance

The following corrosion resistance classes exist:

V1, V2, V3, Vm LXXXXX

This classification relates to the durability of the chimney liner against corrosion and offers three classes V1, V2, V3 as well as allowing the manufacturer to self-declare (Vm) the corrosion resistance based on

historical experience and data. The chimney liner material which details material grade and liner thickness is also covered. The classes directly relate to three corrosion tests depending on the type of fuel being used. There are as follows:

- V1-Gas: Sulphur content \leq 50mg/m³, natural gas L+H Kerosene: Sulphur content \leq 50mg/m³
- V2- Gas: Natural gas L+H Oil: Sulphur content \leq 0.2 mass % Kerosene: Sulphur content \geq 50mg/m³ Wood in open fireplaces.
- V3- Gas: Natural gas L+H Oil: Sulphur content $>$ 0.2 mass % Kerosene: Sulphur content \geq 50mg/m³ Wood in open fireplaces. Wood in closed stoves, Coal Peat.
- Vm- Self declared by the manufacturer as suitable for the application based on product history and historical performance in the field.

The corrosion resistance class should be matched against the fuel type.

The liner specification

The liner specifications offer a number of material codes together with the liner thickness. A typical liner for multi-fuel application would be L50 040, indicating a 316L grade stainless steel liner of 0.4mm thickness.

Soot fire resistance

The following soot fire resistance classes exist:

- G[X] = with soot fire resistance
- O[X] = without soot fire resistance

[X]=product declared minimum distance to combustible material in mm.

To obtain the “G” classification, the product has to be tested at 1000°C for 30 minutes and remain intact, whilst the temperature of a piece combustible material placed at the designated distance does not exceed 100°C at an ambient temperature of 20°C. For solid fuel applications, the chimney system must be soot fire resistant and have a G(x) designation. The distance to combustible (X) will vary depending on individual manufacturer’s products, however a quality product would typically have a classification of G(50).

Example BS EN 1856-1 designations for Poujoulat Therminox:

- Therminox TI: BS EN 1856-1 T450 N1 W V2 L50040 G50 (without seals)
- Therminox TI: BS EN 1856-1 T250 P1 W V2 L50040 O20 (with seals)
- Therminox TI: BS EN 1856-1 T250 N1 W V2 L50040 O20 (without seals)

THERM-INOX	<i>sans joint / ohne Dichtung / without seal / Zonder afdekking / sine joints / Senza guarnizioni</i>	<i>joint / mit Dichtung / seal / Met afdekking / joints / guarnizioni</i>
TI	T450 NI W V2-L50040* G50	
TI	T250 NI W V2-L50040* O20	T250 P1 W V2-L50040 O20**
ZI	T450 NI W V2-L50040* G50	
ZI	T250 NI W V2-L50040* O20	T250 P1 W V2-L50040 O20**
TR	T160 NI W Vm-L20040 O20	T160 P1 W Vm-L20040 O20
ZR	T160 NI W Vm-L20040 O20	T160 P1 W Vm-L20040 O20

Note : * Ø \geq 400 L --R50 ** Gaz, gas = silicone ; Fuel, oil, BI, gasoline, gasolio, stookolie = FPM viton type

SIZING CHARTS

It is vital to the correct and efficient operation of an appliance that the correct sized chimney is installed. The sizing chart below should help you make the right choice when installing open fires. When installing any appliance you must always follow the manufacturer's recommendations and never install a chimney that is smaller than the spigot of the appliance.

The total opening area of a fireplace is equal to the sum of all the open areas. For example; A fireplace with four open sides:

The total opening area = side area 1+ side area 2+ side area 3 + side area 4.

Side area = Height x Width

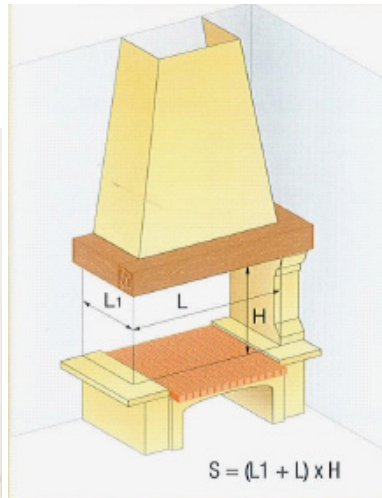
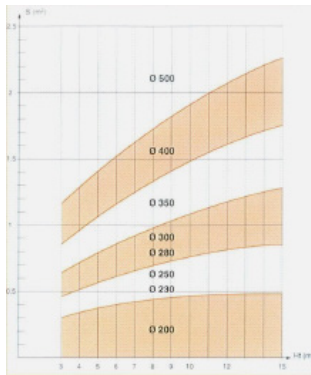

Offsets in Chimneys:

In all flue systems offsets should be used with care, using the guidelines below will help:

- Use a maximum two offsets in any flue system.
- No offset should be at more than 45° angle.
- Each manufacturer will have components to allow the construction of offsets. Ensure that you understand how to use these components and follow the installation instructions carefully.

Chimney Outlets

The outlet of a chimney must be a minimum of 4.5m above the outlet of the appliance. The exact location of the flue outlet depends on the type of fuel being used and the location of the outlet in relation to the building and surrounding structures. Check part L for further details and diagrams.

Part J: Flue outlet positions for solid fuel appliances.

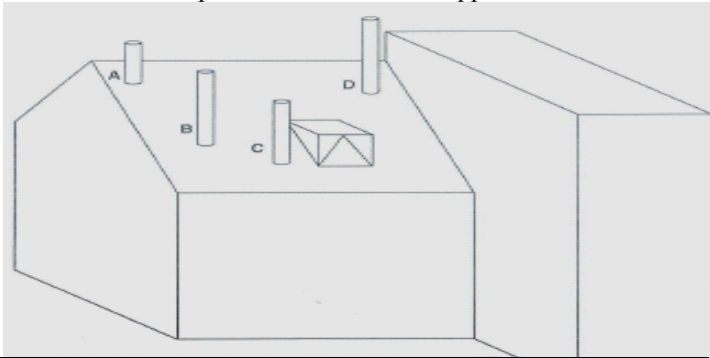



Point where flue passes through weather surface (Notes 1,2)		Clearances to flue outlet
A	At or within 600mm of the ridge.	At least 600mm above the ridge.
B	Elsewhere on a roof(whether pitched or flat)	At least 2300mm horizontally from the nearest point on the weather surface and: <ul style="list-style-type: none"> a) at least 1000mm above the highest point of intersection of the chimney and the weather surface; or b) At least as high as the ridge.
C	Below (on a pitched roof) or within 2300mm horizontally to an open able rooflight, dormer window or other opening.	At least 1000mm above the top of the opening.
D	Within 2300mm of an adjoining or adjacent building, whether or not beyond the boundary.	At least 600mm above the adjacent building.
Notes 1) The weather surface is the building external surface, such as its roof, tiles or external walls. 2) A flat roof has a pitch less than 10° 3) The clearances given for A or B, as appropriate, will also apply.		

Chimney Data Plate

The installer has the responsibility to put in plain view a data plate with all the details of the flue system, the product used and performance it can achieve. A data plate must be installed for any type of flue installation.

An example of a Poujoulat data plate is shown below.

 POUJOULAT N°1 IN EUROPE FOR CHIMNEY SYSTEMS	BP 01 F 79270 Saint-Symphorien Tel. +33 (0) 5 49 04 40 40 www.poujoulat.fr	THERM-INOX Cheminée / Chimney / Schornstein - EN 1443 Ø _____ mm
<input type="checkbox"/> TI <input type="checkbox"/> ZI	<input type="checkbox"/> TR <input type="checkbox"/> ZR	
<input type="checkbox"/> T450 N1 D 3 G50	<input type="checkbox"/> T160 N1 W 2 020	
<input type="checkbox"/> T250 N1 W 2 020	<input type="checkbox"/> T160 P1 W 2 020	
<input type="checkbox"/> T250 P1 W 2 020		
Installateur / Installer Nom / Name _____	Installation Date / Datum _____	
Adresse / Address _____ _____	Distance aux matériaux combustibles Distance to combustible materials Abstand zu brennbaren Werkstoffen _____ mm 	

Prefabricated Chimney Tops

The prefabricated chimney top is ready made and adaptable. It allows the appearance of a traditional brick or rendered chimney without the weight or expense of building a masonry chimney.

The prefabricated chimney top must be installed as per the manufacturer's installation instructions and the roofer's specifications.

Poujoulat chimney tops are not made to have a TV antenna anchored to them.

Poujoulat chimney tops come with Poujoulat Chimney sections pre-installed. For this reason we strongly recommend using Poujoulat products from appliance to outlet.

Do not reduce the internal diameter of any flue from the appliance to the outlet.

Lining:

A masonry chimney that is suspected of leaking or is connected to a stove should be re-lined with an appropriate liner conforming to BS EN1856-2. Usually relines are carried out using a flexible stainless steel liner. Any relining work will reduce the cross sectional area of the flue, this must be taken into account before works commence.

Flexible stainless steel liners should only be used for renovation of existing chimneys. This technique should not be used for new build.

Lining preparation

Before lining the chimney, the void should be swept and dried properly.

Note: if the flue-way of the chimney is not clear then the chimney cannot be lined.

Before starting any work, the building and chimney needs to be proved sound and stable. If in doubt consult a structural engineer.

Lining Using Flexible liner

The liner and its accessories must be manufactured in accordance with EN 1856-2 (CE marked) and installed as per local building regulations.

Flexible stainless steel liners used with solid fuel appliances must twin skinned.
Flexible liner must be installed in one continuous length (no joiner allowed).

Rigid Liners

Relining may also use rigid liners (such as Poujoulat Condensor or IsoKern) - Rigid flue liners must be installed as per the manufacturer's guidance and the building regulations.

Joint between two types of product

When joining two sections of flue product care must be taken to ensure that the new flue section is of the same size diameter or of a larger diameter than the existing flue. Do not reduce the size of a flue.
The joint between flues must be airtight (and if necessary pressure tight) and the joint between flue sections must be designed so that condensates run down inside the flue and not out of the joint.

Annexe A: Air supply.

Sizing of the Air Supply:

All appliances require a supply of air to ensure that the complete combustion of the fuel and that the chimney functions correctly.

In England and Wales guidance for the provision of combustion air is given in Document J of the building regulations. The amount of combustion air required varies with the type of appliance, the fuel being used and the output of the appliance.

Extractor fans should not be installed in the same room in which the appliance is installed. (In England and Wales please see part J of the building regulations.)

Annexe B: maintenance and sweep

Requirements:

All domestic solid fuel appliances (even when burning smokeless fuels) require regular and frequent chimney sweeping.

Chimney flues for stoves should be swept minimum twice per year. This is usually once during the usage period and once before the heating season. This is a minimum and many appliances will require more regular maintenance.

Chimney terminals such as ventilated rain caps, rain caps and Aspirotors need to be cleaned at every sweep. To facilitate the sweep, terminals should be removable or should be designed or installed to allow the chimney to be swept. The sweep should be performed by a company with recognised accreditation/qualification. (Look for HETAS or NACS membership)

How is a sweep done?

A sweep is done with the help of brushes (please note that Poujoulat do not recommend the use of metallic brushes in their chimney systems) and rods. The sweep is performed to clean the walls of the flue of any soot or tar residue to ensure the efficient working of the chimney and to help avoid a chimney fire.

Sweep certificate

A sweep certificate should to be issued to the owner of the chimney to demonstrate that the cleaning has been done and that the chimney is safe to use. If the works have not been completed then this should be recorded on the sweep certificate along with the reason and any remedial action that is required.

If you have a chimney fire

Call the fire brigade!

After a chimney fire, the whole flue needs to be inspected and swept by a qualified installer who may recommend it is replaced or that remedial works are required. Do not use the chimney until it has been inspected.

Fuel

The appliance manufacturer's operating instructions will indicate the right type of fuel to use and what fuels not to use.

Only burn wood that has been seasoned for 18 to 24 months. Wet or under-seasoned wood will cause excessive tar and corrosion of the chimney and increases the risk of chimney fires. Do not burn salvage wood as the chemicals used to treat the wood may harm the appliance or chimney.

Never burn wet coal.

Why use wood for energy?

Wood is the third energy source after oil & coal & is the most environmentally friendly.

4 reasons to use wood:

1. It is cheap, wood is the cheapest fuel per KWh.
2. It is a renewable source of energy. This allows us to save on fossil fuels, and reduce our carbon footprint.
3. It gives instant heat a fire can be burning brightly in a matter of minutes.
4. It is a convivial, pleasurable and energy adapted to modern life.

References.

- the Health and Safety at Work Act 1974 (as amended) which requires the installer to exercise a duty of care to their customers as well as their employees.
- Building regulations part J1, J2, J3, J4 covers Combustion appliances and fuel storage system for Wales and England and is approved by the Government.
- Building regulations Part L for system design and appliance efficiency and is an approved document.
- NB: Building regulations for Scotland and Northern Ireland differ slightly from those for England and Wales, and precise details should be checked for compliance.
- BS EN 1856-1 and 2- solid fuel
- BS 8303 for open fires

Further Help and Assistance:

Poujoulat Technical Service:

Phone: 01483 461700

Fax: 01483 533435

Email : technical@poujoulat.co.uk